

GENERAL DESCRIPTION

The L432 is a three-terminal adjustable shunt regulator utilizing an accurate 1.24V band gap reference. The output voltage can be set to any value between 1.24V (V_{REF}) to 18V with two external resistors as shown in the typical application circuit. The device exhibit a wide operating current range of 0.2 to 100 mA with a typical dynamic impedance of 0.25 Ω . Active output circuitry provides a very sharp turn-on characteristic, making the L432 excellent replacements for low-voltage zener diodes in many applications, including on-board regulation and adjustable power supplies.

When used with an opto-coupler, the L432 is ideal voltage reference in isolated feedback circuits for 3.3V switching-mode power supplies. The L432 shunt regulator is available in two voltage tolerances (0.5% & 1.0%) and three package options (TO-92, SOT-23-3 and SO-8).

FEATURES

- Internal amplifier with 100 mA capability
- Programmable output voltage to 18V
- 0.25 Ω typical output impedance
- Pin to pin compatible with TLV431A, TS431, SC431L & AS432
- Trimmed bandgap design 0.5% & 1.0% with three package options
- Low output noise

APPLICATIONS

- Linear regulator controller
- Precision voltage reference
- Switching power supplies
- Battery operating equipment
- Instrumentation
- PCs, Computer disk drives

SYMBOL & BLOCK DIAGRAM

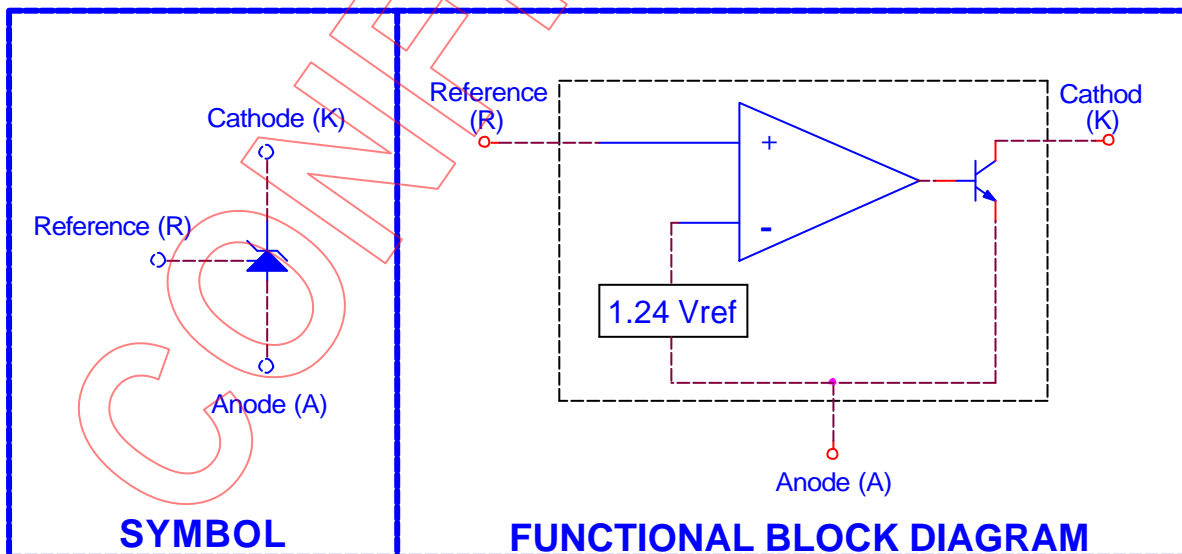

ABSOLUTE MAXIMUM RATINGS

PARAMETER	VALUE
Cathode-Anode Reverse Breakdown Voltage - V_{KA}	20V
Anode-Cathode Forward Current - I_{AK}	1 A
Operating Cathode Current - I_{KA}	100 mA
Reference Input Current - I_{REF}	1 mA
Storage Temperature Range - T_{STG}	-65 to +150 °C
Junction Temperature - T_J	150 °C
Lead Temperature (Soldering, 10 Seconds) - T_L	300 °C
Continuous Power at 25 °C - P_D	
TO-92	700 mW
SOIC-8	650 mW
SOT-23	200 mW

RECOMMENDED CONDITIONS

Parameter	Rating
Cathode Voltage (V_{KA})	V_{REF} to 18V
Cathode Current (I_K)	10 mA

TYPICAL THERMAL RESISTANCES

Package	θ_{JA}	θ_{JC}	Typ. De-rating
TO-92	160 °C/W	80 °C/W	6.3 mW/°C
SOIC-8	175 °C/W	45 °C/W	5.7 mW/°C
SOT-23	575 °C/W	150 °C/W	1.7 mW/°C

ELECTRICAL SPECIFICATIONS

(Ambient temperature must be derated base on power dissipation and package thermal characteristics. The conditions are: $V_{KA} = V_{REF}$ and $I_K = 10$ mA unless otherwise stated)

PARAMETER	TEST CONDITIONS	MIN	TYP	MAX	UNITS	TEST CIRCUIT
Output Voltage - V_{REF}	$T_A = 25$ °C, L432 (0.5%)	1.234	1.240	1.246	V	1
	$T_A = 25$ °C, L432 (1%)	1.228	1.240	1.252		
Line Regulation - ΔV_{REF}	$V_{KA} = V_{REF}$ to 15V		28	50	mV	2
Load Regulation - ΔV_{REF}	$I_K = 1$ to 100 mA		3.9	6	mV	1
Temperature Deviation - ΔV_{REF}	$0 < T_J < 105$ °C		5	12	mV	1
Reference Input Current - I_{REF}			2.3	6	μA	1
Reference Input Current Temperature Coefficient - ΔI_{REF}	$0 < T_J < 105$ °C		0.14	0.6	μA	1
Minimum Cathode Current for Regulation - $I_{K(MIN)}$			0.2	1	mA	1
Off State Leakage - $I_{K(MIN)}$	$V_{REF} = 0V, V_{KA} = 15V$		40	500	nA	3
Dynamic impedance	$V_{KA} = V_{ref}, f = 1kHz$ $I_K = 0.1$ mA to 100 mA		0.25	0.4		1

TEST CIRCUITS

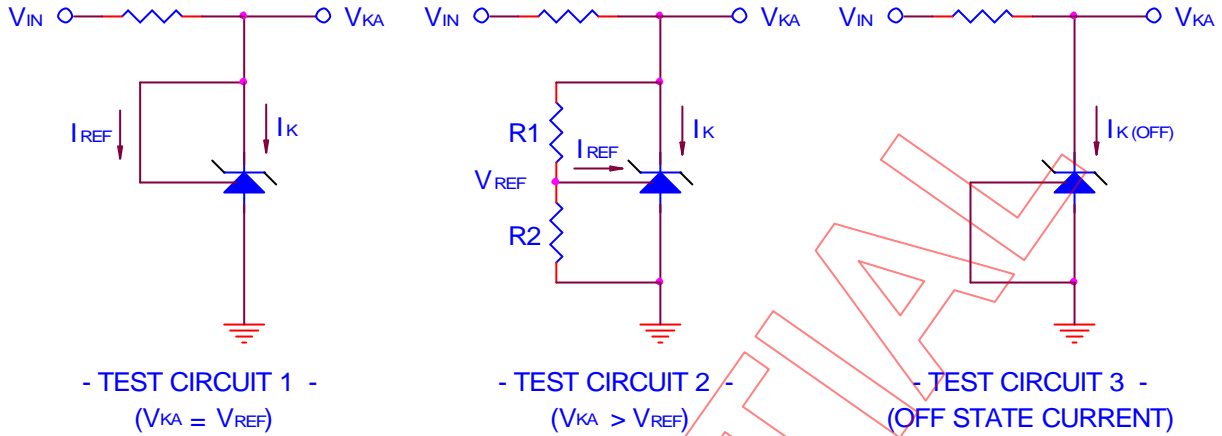

Applications Information – Stability

Selection of load capacitance when using L432 as a shunt regulator

When the L432 is used as a shunt regulator, two options for selection of CL are recommended for optimal stability:

1. No load capacitance across the device, decouple at the load.
2. Large capacitance across the device, optional decoupling at the load.

The reason for this is that L432 exhibits instability with capacitances in the range of 1nF to 1uf (approx.) at light cathode currents (up to 3mA typical). The device is less stable the lower the cathode voltage has been set for. Therefore while the device will be perfectly stable operating at a cathode current of 10mA with a 0.1uF capacitor across it, it will oscillate transiently during start-up as the cathode current passes through the instability region. Selecting a very low

(or preferably, no)capacitance, or alternatively a high capacitance (such as 10uF) will avoid this issue altogether. Since the user will probably wish to have local decoupling at the load anyway, the most cost effective method is to use no capacitance at all directly across the device. PCB trace/via resistance and inductance prevent the local load decoupling from causing the oscillation during the transient start-up phase. Note : if the L432 is located right at the load, so the load decoupling capacitor is directly across it, then this capacitor will have to be 100pF or 1uF.

Small-Signal Gain and Phase Shift
VS. Frequency

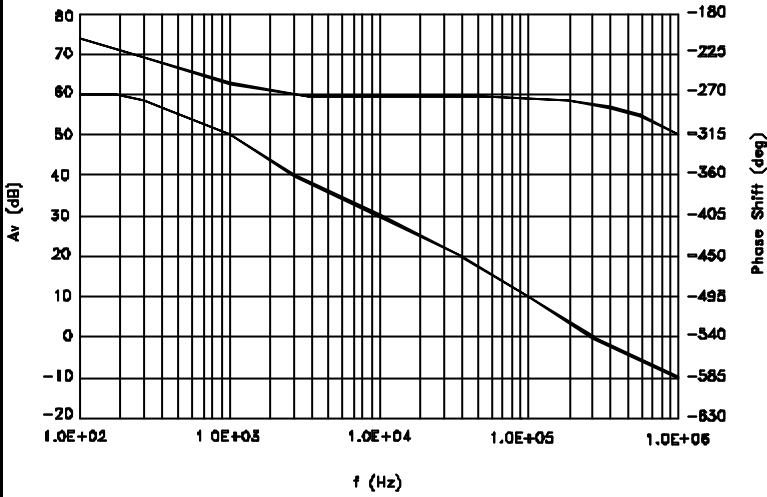

Test Circuit for Small Signal Gain and Phase

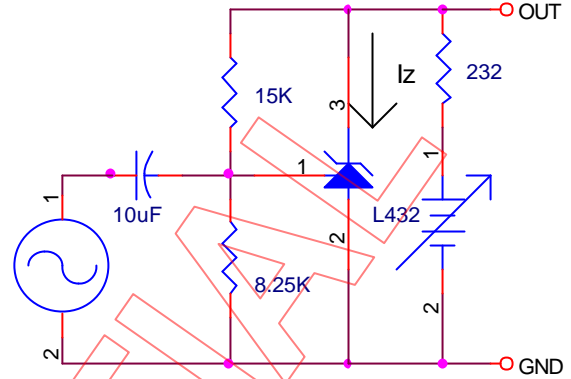

Stability Boundary Condition For Shunt Regulation
VS. Cathode Current and Load Capacitance

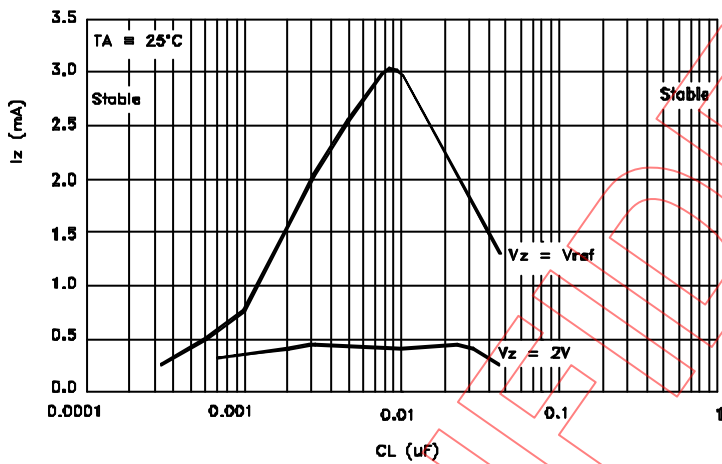

Test Circuit for Stability

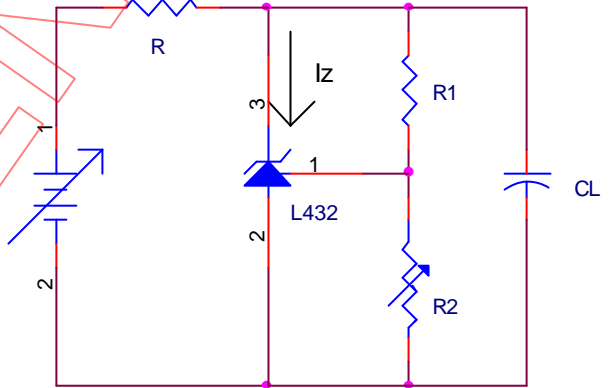

Cathode Current
VS. Cathode Voltage

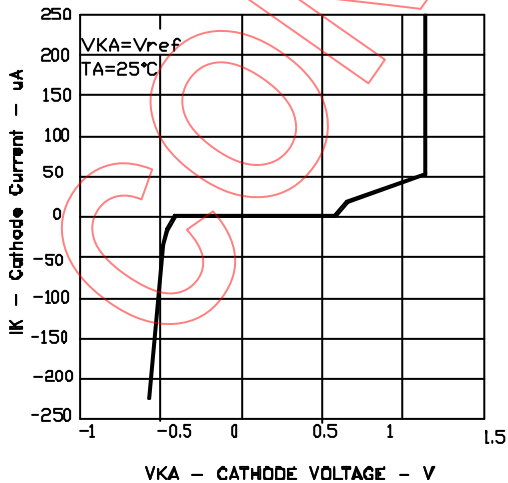

Cathode Current
VS. Cathode Voltage

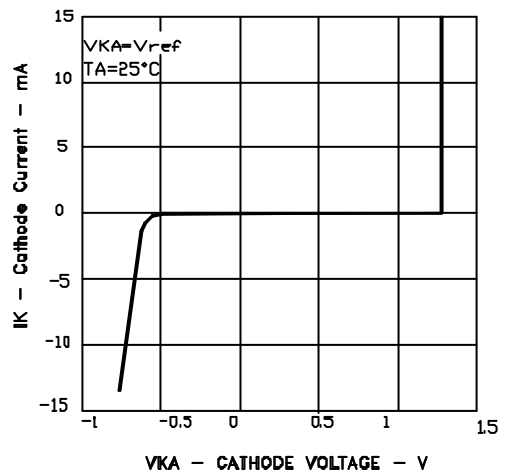

Reference Voltage
VS. Junction Temperature

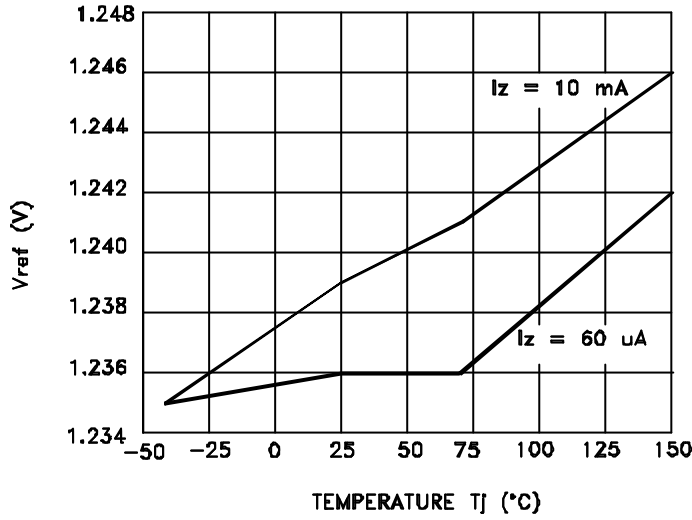

Reference Impedance
VS. Frequency

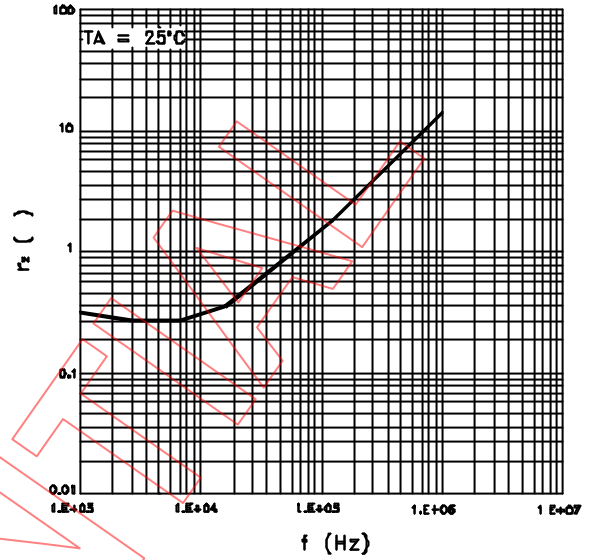

Ratio of Delta Reference Voltage to Delta Cathode Voltage
VS. Junction Temperature

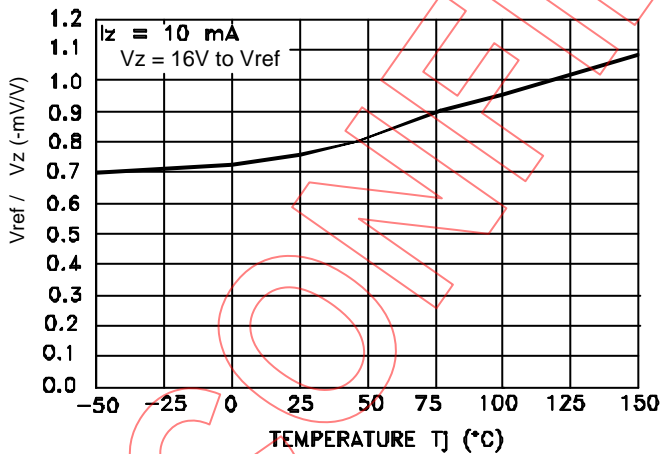

Reference Input Current
VS. Junction Temperature

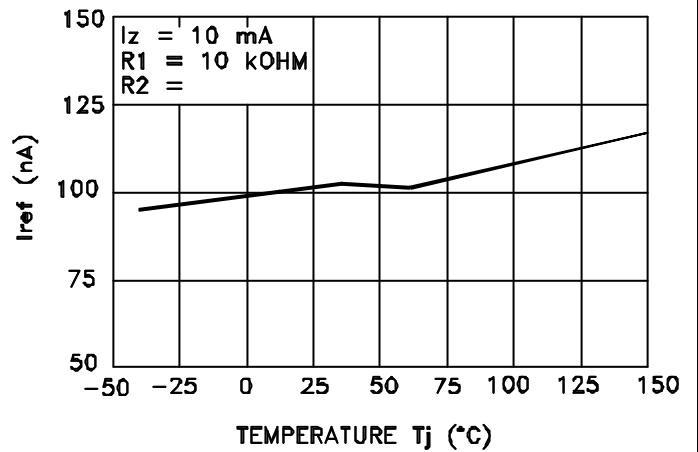

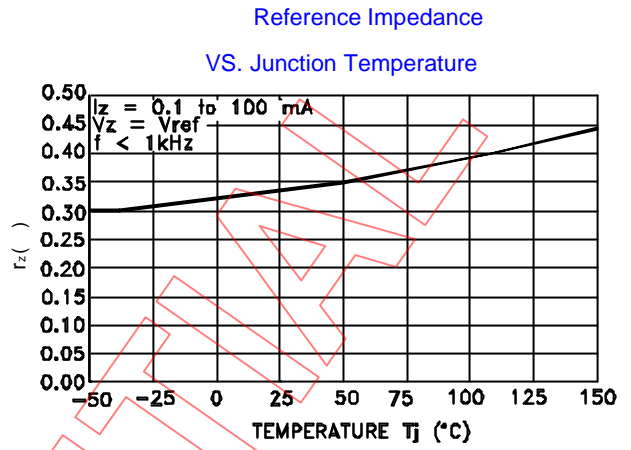
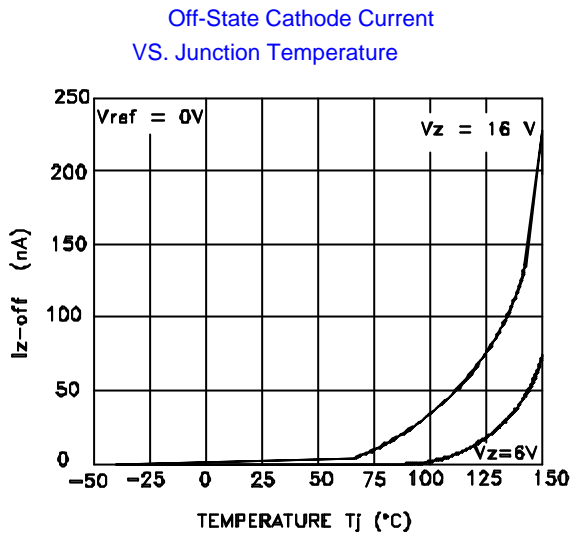

PIN CONFIGURATIONS

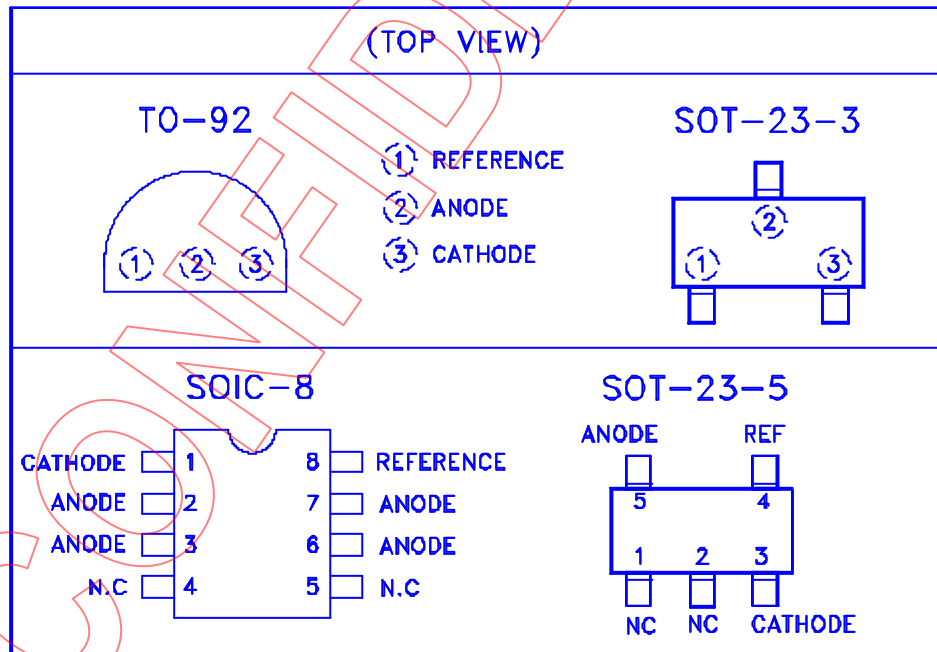

DEVICE SELECTION GUIDE

Device	L432N BG	L432M3 BG	L432V BG	L432M5 BG
Package	TO-92	SOT-23-3	SOIC-8	SOT-23-5
Marking	<u>L432NA</u>	<u>2M3A</u>	L432VG	<u>2M5A</u>
Tolerance	1%	1%	1%	1%

Orders for parts with Lead-Free plating can be placed using the LXXXXXG parts name.

APPLICATION CIRCUIT

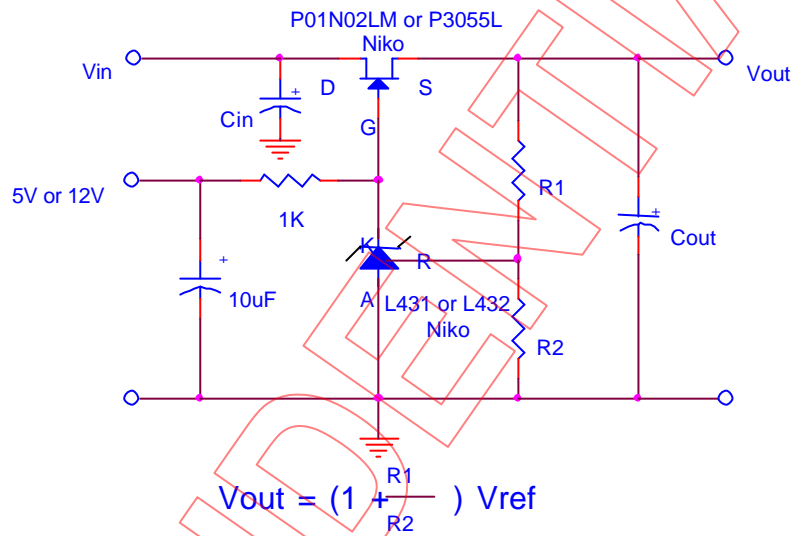

TO-92 MECHANICAL DATA

Dimension	mm			Dimension	mm		
	Min.	Typ.	Max.		Min.	Typ.	Max.
A	4.445		5.207	H	2.413	2.540	2.667
B	4.318		5.334	I	0.356		0.533
C	12.7		15.5	J			
D	0.356		0.533	K			
E	1.143	1.27	1.397	L			
F	3.175		4.191	M			
G	0.762		1.270	N			

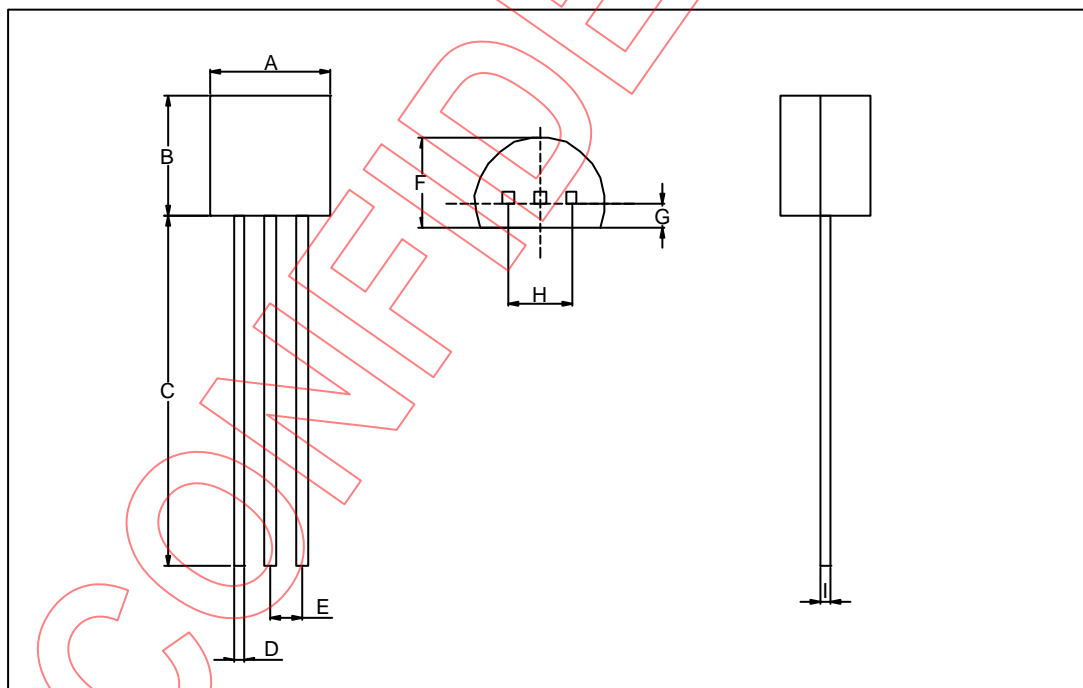

SOT-23 (M3) MECHANICAL DATA

Dimension	mm			Dimension	mm		
	Min.	Typ.	Max.		Min.	Typ.	Max.
A	0.85		1.15	H	0.1	0.15	0.25
B	2.4		3	I	0.37		
C	1.4	1.6	1.8	J			
D	2.7	2.9	3.1	K			
E	1	1.1	1.3	L			
F	0		0.1	M			
G	0.35		0.5	N			

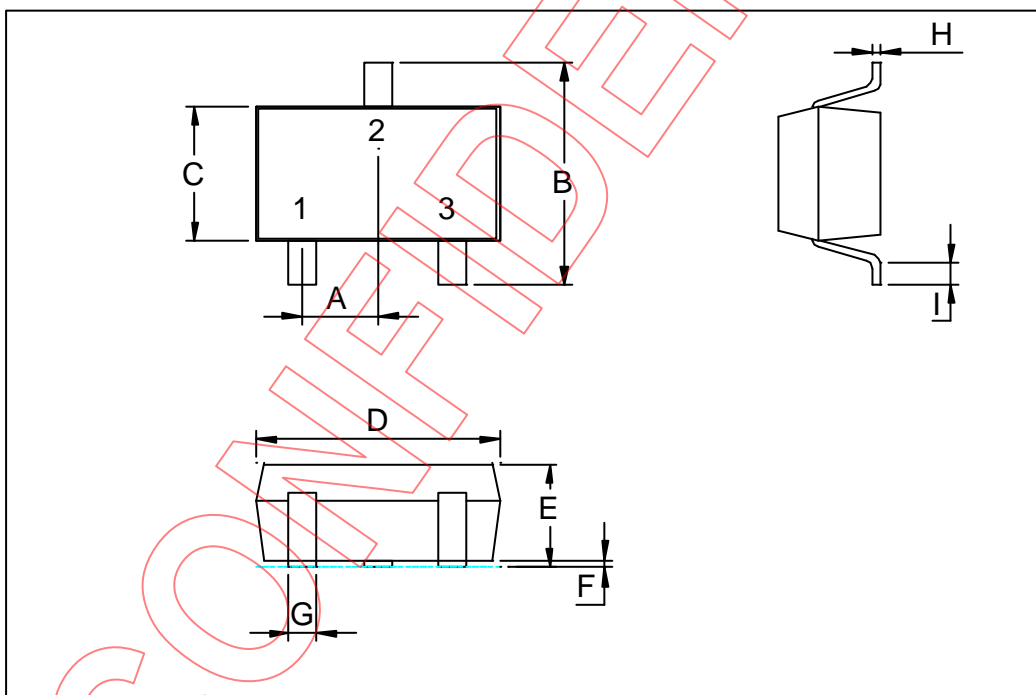

SOIC-8(D) MECHANICAL DATA

Dimension	mm			Dimension	mm		
	Min.	Typ.	Max.		Min.	Typ.	Max.
A	4.8	4.9	5.0	H	0.5	0.715	0.83
B	3.8	3.9	4.0	I	0.18	0.254	0.25
C	5.8	6.0	6.2	J		0.22	
D	0.38	0.445	0.51	K	0°	4°	8°
E		1.27		L			
F	1.35	1.55	1.75	M			
G	0.1	0.175	0.25	N			

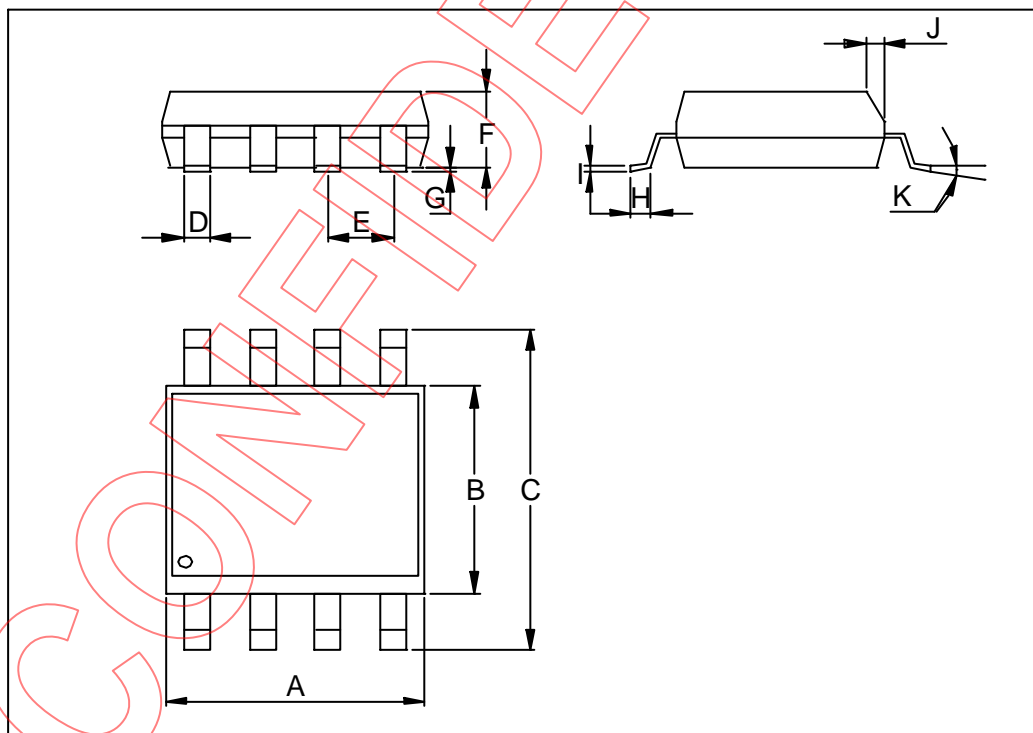

SOT-23 (M5) MECHANICAL DATA

Dimension	mm			Dimension	mm		
	Min.	Typ.	Max.		Min.	Typ.	Max.
A	1.0	1.10	1.30	e		1.90(TYP)	
A1	0.00		0.10	H	2.60	2.80	3.00
A2	0.70	0.80	0.90	L	0.37		
b	0.35	0.40	0.50				
C	0.10	0.15	0.25				
D	2.70	2.90	3.10				
E	1.40	1.60	1.80				

